

**INTRODUCTION**

The basic operation of a multiple winding, multiple tap transformer will be investigated during this experiment. Initially the transformer will be operated under open-circuit conditions to determine the effective turns-ratio between several pairs of windings. The transformer will then be configured for “step-down” operation to investigate the relationship between the source and the load voltages and currents with respect to the turns-ratio of the transformer. Finally, the transformer will be reconfigured for “step-up” operation and the same investigation will be performed.

In this lab you will be using:

- Lab-Volt Transformer EMS 8341
- Lab-Volt Power Supply and Data Acquisition System
- Fluke Model 87 Multimeter

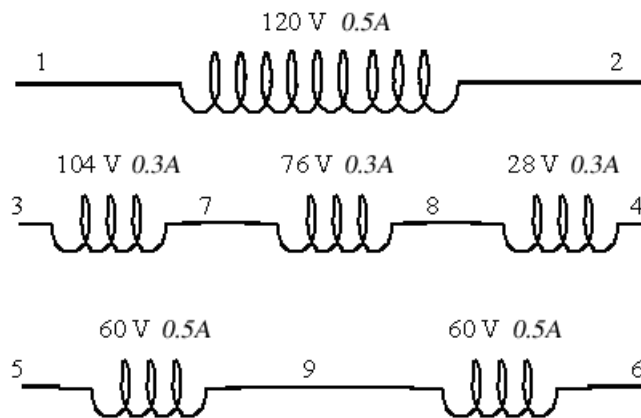

**Figure 9.1 - EMS 8341 Transformer Connections and Voltage Ratings.**

Note - information showing the number of turns for each winding in a transformer is often not provided by the manufacturer of the transformer. Instead, the manufacturer provides the transformer’s “ratings”, from which the turns-ratio information can be derived since the turns-ratio between two specific windings of within a transformer is directly proportional to the ratio of the rated voltages of those windings. Thus, the effective turns-ratio between two windings can be determined by:

$$\text{turns ratio} = a = \frac{N_P}{N_S} = \frac{V_{P(\text{rated})}}{V_{S(\text{rated})}}$$

where  $V_{P(\text{rated})}$  is the rated voltage of the primary winding and  $V_{S(\text{rated})}$  is the rated voltage of the secondary winding. Both the voltage and current ratings of the individual windings within the EMS 8341 transformer are shown in Figure 9.1.

## PROCEDURE

**Turns Ratio Investigation** – during this portion of the experiment, winding **1-2** will be considered the primary winding and the turns-ratio will be determined between the primary winding and various secondary windings over a range of operational voltages.

1. Connect the variable AC source (terminals **4** and **5**) to winding **1-2** of the transformer while leaving all of the other transformer terminals “open-circuited”. Configure a “handheld multimeter to measure the voltage across winding **1-2**, which is equivalent to the AC source voltage.
2. Configure the data acquisition system to measure the voltages across windings **3-4**, **5-6**, and **5-9**.
3. Vary the primary winding voltage from **60V to 180V in 60V increments** and **measure the voltage across secondary windings 3-4, 5-6 and 5-9**. Record the results in Table 7.1.
4. Reduce the supply voltage to zero and turn **OFF** the source. Do NOT proceed past this step until your instructor has verified your results.

**“STEP-DOWN” OPERATION** – during this portion of the experiment, winding **1-2** will be considered the primary winding and winding **5-9** will be considered the secondary winding. The transformer will be used to supply a **120Ω** load at various voltage levels in order to investigate the relationship between the primary and secondary voltages and currents.

5. Connect the AC source (terminals **4** and **N**) to winding **1-2** of the transformer and connect a **120Ω** resistor (**600Ω||300Ω||300Ω**) across winding **5-9**. Configure the data acquisition system to measure the voltages across windings **1-2** and **5-9**, and the currents flowing through windings **1-2** and **5-9**.
6. Set the source voltage to **60V** and **measure the voltage across winding 5-9 and the currents in windings 1-2 and 5-9**. Record the results in Table 7.2.
7. Increase the source voltage to **120V** and **repeat the previous measurements**.
8. Reduce the supply voltage to zero and turn **OFF** the source. Do NOT proceed past this step until your instructor has verified your results.

**“STEP-UP” OPERATION** – during this portion of the experiment, winding **5-9** will be considered the primary winding and winding **1-2** will be considered the secondary winding. The transformer will be used to supply a **600Ω** load at various voltage levels in order to investigate the relationship between the primary and secondary voltages and currents.

9. At the transformer, switch the wires plugged into terminals **1** and **2** with the wires plugged into terminals **5** and **9**, **but make no other changes to your circuit**. This will reconfigure the transformer such that the source is connected to winding **5-9** and the load resistance to winding **1-2**.
10. **Reconfigure the load resistor to 600Ω. ←(Switch OFF both of the 300Ω resistors)**
11. Set the source voltage to **30V** and **measure the currents in windings 5-9 and 1-2 along with the winding 1-2 voltage**. The raise the source voltage to **60V** and **repeat the measurements**. Record your measured results in Table 7.3.
12. Reduce the supply voltage to zero and turn **OFF** the source.

V <sub>1-2</sub> (volts)	V <sub>3-4</sub> (volts)	V <sub>5-6</sub> (volts)	V <sub>5-9</sub> (volts)
60			
120			
180			

**Table 7.1 – Open Circuit Voltages**

V <sub>1-2</sub> (volts)	V <sub>5-9</sub> (volts)	I <sub>1-2</sub> (amps)	I <sub>5-9</sub> (amps)
60			
120			

**Table 7.2 – Step-Down Transformer Voltages and Currents**

V <sub>5-9</sub> (volts)	V <sub>1-2</sub> (volts)	I <sub>5-9</sub> (amps)	I <sub>1-2</sub> (amps)
30			
60			

**Table 7.3 – Step-Up Transformer Voltages and Currents**

**Verified by:** \_\_\_\_\_ **(Instructor’s Initials)**

(Initials NOT required for Online Version)

**REPORT GUIDELINES:**

For this experiment, you are required to submit:

1. This page as a **cover sheet**. (Be sure to write your name in the space provided at the top of the page.)

Then, complete the following steps and submit the results, **in order**, with all pages stapled to the back of the cover-page. Note that the results must be computer-generated (i.e. – NOT hand-written/hand-drawn).

2. **Plot** of all of the **measured voltages** (Table 7.1) **as a function of V<sub>1-2</sub>** on a **single graph**.

**Discuss** whether or not the plot confirms the theoretical expectations (based on the rated voltages).

3. For the measured values recorded in Table 7.2, **determine** the **ratio** of the **voltages V<sub>1-2</sub>/V<sub>5-9</sub> (V<sub>P</sub>/V<sub>S</sub>)** and the **currents I<sub>1-2</sub>/I<sub>5-9</sub> (I<sub>P</sub>/I<sub>S</sub>)** at both applied voltages and **tabulate** the results (create a new table). The first column of your table should display the primary voltage setting (value) at while the ratios were calculated, and the remaining two columns should display the voltage and current ratio values. Be sure that the first row of the table is a header that identifies the values contained in each column.

**Determine** the **relative difference** between each of the ratios calculated from your measured values and the expected ratios based on the transformer’s ratings and **tabulate** the results.

**Discuss** whether or not the results adhere to your expectations for the transformer.

4. For the measured values recorded in Table 7.3, **determine** the **ratio** of the **voltages V<sub>5-9</sub>/V<sub>1-2</sub> (V<sub>P</sub>/V<sub>S</sub>)** and the **currents I<sub>5-9</sub>/I<sub>1-2</sub> (I<sub>P</sub>/I<sub>S</sub>)** at both applied voltages and **tabulate** the results.

**Determine** the **relative difference** between each of the ratios calculated from your measured values and the expected ratios based on the transformer’s ratings and **tabulate** the results.

**Discuss** whether or not the results adhere to your expectations for the transformer.

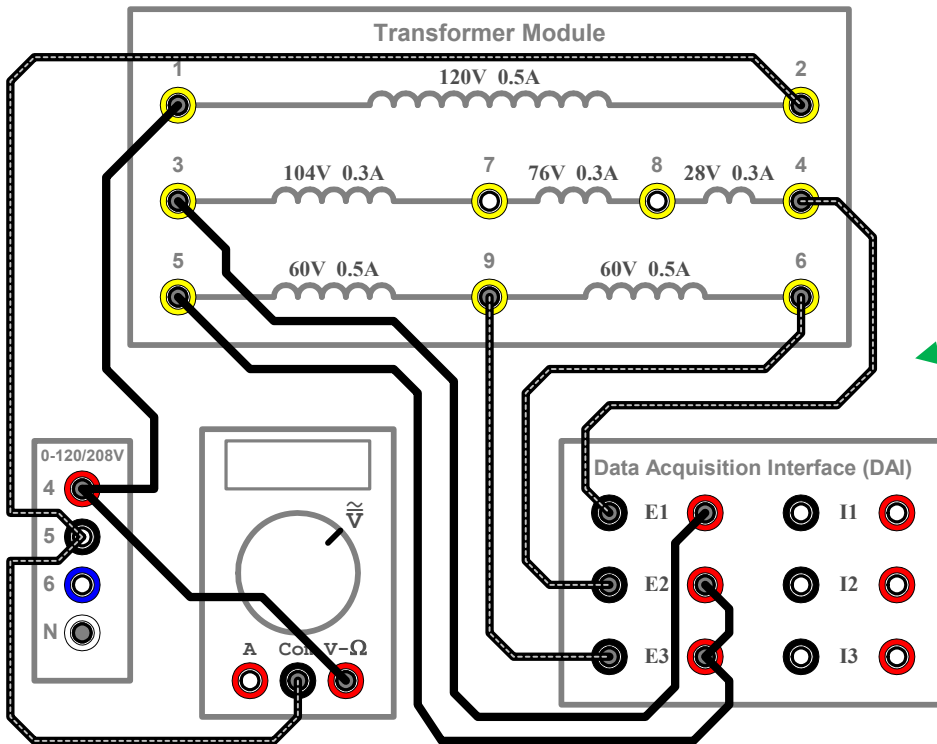

**Turns-Ratio Investigation**

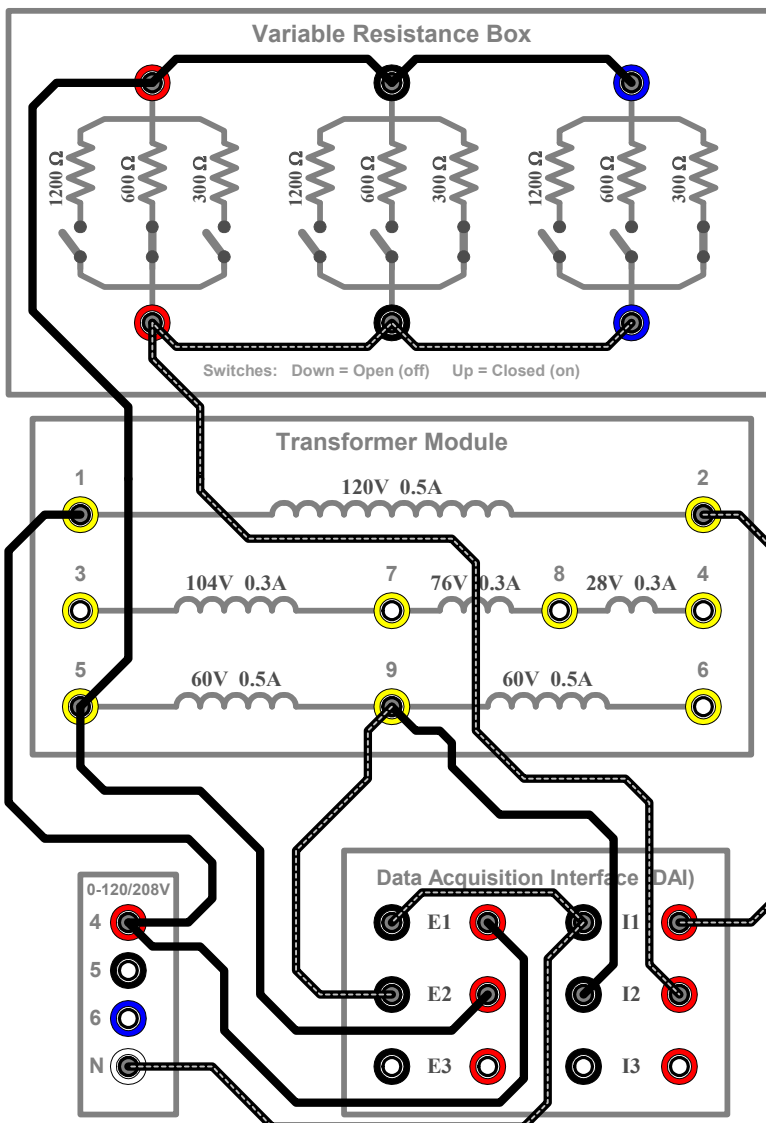

**"Step-Down" Operation**